



HEAVY DUTY BELT SANDER

MODEL NO: CAT70

PART NO: 3110750

OPERATING & MAINTENANCE INSTRUCTIONS



DL1222 R3

INTRODUCTION

Thank you for purchasing this CLARKE Air Sander.

The CAT70 Sander is ideal for use in garages and workshops. The narrow belt and adjustable handle allow access in awkward places.

Before attempting to use this product, please read this manual thoroughly and follow the instructions carefully. In doing so you will ensure the safety of yourself and that of others around you, and you can look forward to your purchase giving you long and satisfactory service.

IMPORTANT

Please read all of the safety and operating instructions carefully before using this product. The following safety symbols are to be found on the packaging.

	Wear eye protection		Wear dust mask.
--	---------------------	--	-----------------

GUARANTEE

This product is guaranteed against faulty manufacture for a period of 12 months from the date of purchase. Please keep your receipt which will be required as proof of purchase.

This guarantee is invalid if the product is found to have been abused or tampered with in any way, or not used for the purpose for which it was intended.

Faulty goods should be returned to their place of purchase, no product can be returned to us without prior permission. This guarantee does not effect your statutory rights.

GENERAL SAFETY RULES



CAUTION: FAILURE TO FOLLOW THESE PRECAUTIONS COULD RESULT IN PERSONAL INJURY, AND/OR DAMAGE TO PROPERTY.

WORK ENVIRONMENT

1. Keep the work area clean and tidy.
2. Dress appropriately - Do not wear loose clothing or jewellery. Tie long hair out of the way.
3. Keep children and visitors away - Do not let children handle the tool.
4. Do not operate the sander where there are flammable liquids or gases.

USE OF POWER TOOLS

1. Stay alert and use common sense - do not operate the tool when you are tired or under the influence of alcohol, drugs or medication.
2. Always wear eye protectors when using the sander. Eye protectors must provide protection from flying particles from the front and the side. Ear protectors should also be worn.
3. Do not overreach - Keep proper footing and balance at all times.
4. Never use oxygen, CO², combustible gasses or any type of bottled gas as a source of power for this tool.
5. Do not connect the air supply hose with your finger on the trigger.
6. Do not exceed the maximum pressure for the tool of 90 psi / 6.2 bar.
7. Check hoses for leaks or worn condition before use, and ensure that all connections are secure.
8. Keep the air supply hose away from heat, oil and sharp edges.
9. Do not use the tool for any purpose than that described in this manual.
10. Do not fit the tool to any stand or clamping device that may damage it.
11. Do not carry out any alterations or modifications to the tool.
12. Always disconnect from the air supply when:
 - Performing any maintenance
 - The tool is not in use.
 - The tool will be left unattended.

- Moving to another work area.
 - Passing the tool to another person.
13. Never use the tool if it is defective or operating abnormally.
 14. This tool should be serviced at regular intervals by qualified personnel.
 15. Avoid damaging the tool by applying excessive force of any kind.
 16. Always maintain the tool with care. Keep it clean for the best and safest performance.
 17. Quick change couplings should not be located at the tool. They add weight and could fail due to vibration.
 18. DO NOT force or misuse the tool. It will do a better and safer job at the rate for which it was designed.
 19. Do not remove any labels. Damaged labels should be replaced.
 20. This tool vibrates with use. Vibration may be harmful to your hands or arms. Stop using the tool if discomfort, a tingling feeling or pain occurs. Seek medical advice before resuming use.

SANDER-SPECIFIC SAFETY RULES

1. Inspect the sanding belt before use. Do not use if frayed.
2. Avoid contact with the moving sanding belt and wear suitable gloves to protect the hands.
3. Never run the tool unless the abrasive belt is applied to the workpiece.
4. Beware of potentially explosive atmospheres being caused by dust / fumes resulting from sanding and used dust extraction systems where possible.
5. Always wear a face mask when using the sander as protection from airborne particles of sanded material. Avoid disturbing existing dust and minimise the scattering of dust in the workplace environment. Take steps to control the dust at the point of emission.

TRANSPORT & STORAGE

1. Never carry the tool by the air hose.
2. Never carry the tool with your finger on the trigger.
3. When not in use the tool must be disconnected from the air supply and stored in a dry place out of the reach of children (preferably in a locked cabinet).
4. Avoid storing the tool where the temperature is below 0°C.

OVERVIEW

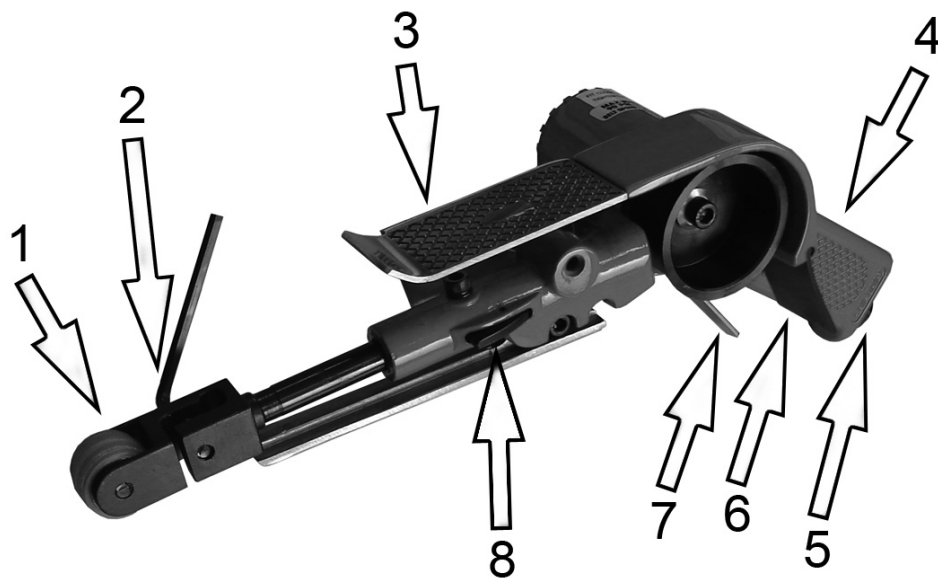

Note: machine shown without belt fitted

NO	DESCRIPTION	NO	DESCRIPTION
1	Idle Pulley	5	Airline Connector
2	Tracking Screw (Allen Key fitted)	6	Dust Guard
3	Finger Pad	7	Throttle Lever
4	Adjustable Handle	8	Tension Bar Release Button

When unpacking the tool, any damage or deficiency should be reported to your CLARKE dealer immediately. The carton contains:

- Sander
- 80 and 100 grit sanding belts
- Allen key

Your sander has been designed to give long and trouble free service. If, however, having followed the instructions in this booklet carefully, you encounter problems, take the unit to your local CLARKE dealer.

COMPRESSED AIR REQUIREMENTS



WARNING: COMPRESSED AIR CAN BE DANGEROUS. ENSURE THAT YOU ARE FAMILIAR WITH ALL PRECAUTIONS RELATING TO THE USE OF COMPRESSORS AND COMPRESSED AIR SUPPLY.

- Use only clean, dry, regulated compressed air as a power source.
- Air compressors used with the tool must comply with the appropriate European Community Safety Directives.
- A build-up of moisture or oil in the air compressor will accelerate wear and corrosion in the tool. Ensure any moisture is drained from the compressor daily and the inlet filter is kept clean.
- If an unusually long air hose is required, (over 8 metres), the line pressure or the hose inside diameter may need to be increased.
- The air hose must be rated at least 150% of the maximum operating pressure of the tool.

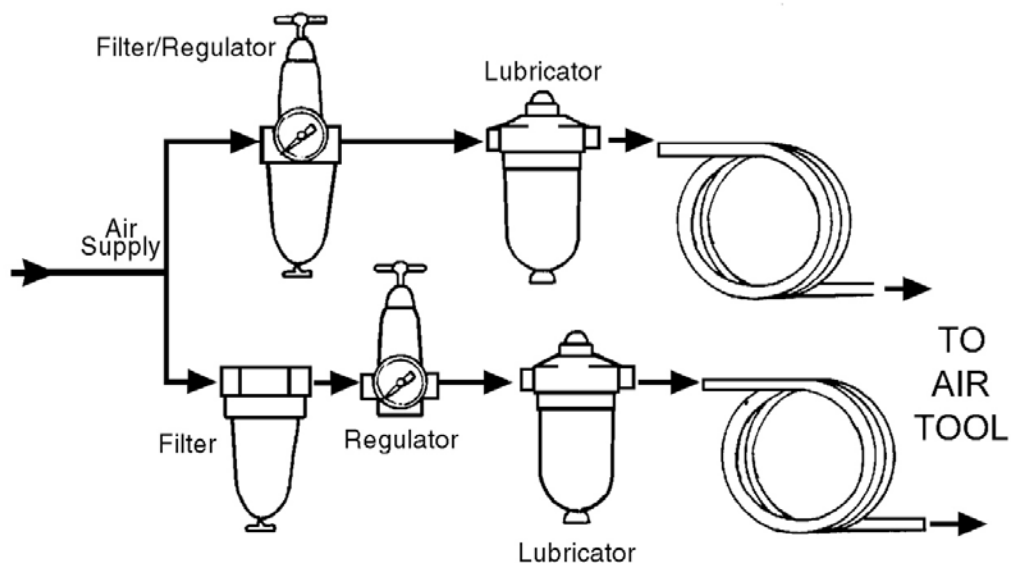

- A typical air line layout is shown above. If an automatic in-line filter/regulator is used, it will keep the tool in good condition, but should be regularly checked and topped up with oil. Clarke airline oil should be used, and the lubricator adjusted to approx 2 drops per minute.
- For optimum performance it is recommended that a 3/8" ID hose is used.
- Never exceed the maximum operating pressure for the tool. It is recommended that air pressure to this tool does not exceed 90 psi at the tool when running. Higher pressures and dirty air will shorten the life of the tool due to faster wear and is a possible safety hazard.

BEFORE USE

CONNECTING THE AIR SUPPLY



WARNING: COMPRESSED AIR CAN BE DANGEROUS. ENSURE THAT YOU ARE FAMILIAR WITH ALL PRECAUTIONS RELATING TO THE USE OF AIR COMPRESSORS AND COMPRESSED AIR SUPPLY.

1. Pour 2-3 drops of CLARKE airline oil into the air inlet. This should be done regardless of whether or not a lubricated air supply is to be used.

2. Connect a suitable hose to the tool as shown using the airline connector supplied with the tool.

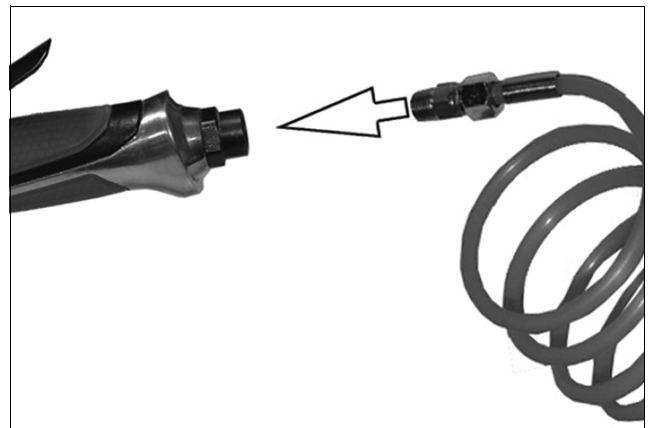

3. If required, connect an in-line mini oiler to the tool.

- A mini oiler helps to prolong the life of the air tool. Remove the oil fill screw from the side of the mini oiler and fill with air-line oil available from your CLARKE dealer. Replace the screw before using the tool.

4. If a mini-oiler is not being used, run a few drops of oil through the tool before use. It can be entered through the inlet strainer or via the hose at the nearest connection to the air supply.

5. Connect the other end of the hose to the compressor.

6. Turn on the air supply and check for air leaks. Rectify any found before proceeding. PTFE tape may be useful for sealing threaded connections.

7. Your air tool is now ready for use.

- You can fit a whip hose with a quick fit coupling if required (available from your Clarke dealer.)

INSTALLING THE BELT

1. To replace sanding belt, push the idler pulley assembly (Item 2) towards the handle until it clicks into the secured position. Replace the belt and press the tension bar (item 14), to re-tension the belt (see Fig 1

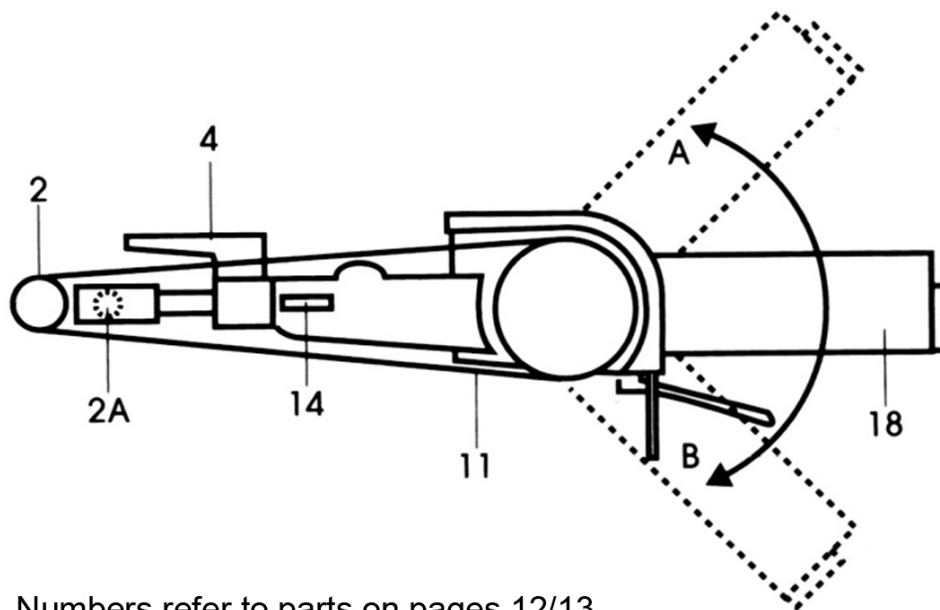

Numbers refer to parts on pages 12/13

2. To track the belt, adjust as required with screw and locknut (2A in Fig 1).
3. To adjust the handle position, slacken the screw (item 11), rotate the handle to the required position. (**Only as far as A or B**), then secure by re-tightening the screw (item 11).
4. Connect to the airline and turn the air on.
5. Ensure your fingers are clear of the sanding belt. Squeeze the throttle lever to start the motor. Allow the motor to reach max speed before offering the belt to the workpiece.
6. Do not use the finger pad (Item 4) to exert pressure on the belt; this item is only for guiding the tool.
7. When finished sanding, release the throttle lever and allow the motor to stop before carefully putting the tool down.
 - **Only use sanding belts designed for use with this type of sander**

OPERATING

1. Squeeze the trigger against the body of the tool to start the sander and control the speed. Evaluate the speed and adjust to suit.
2. To begin work, rest the belt on the workpiece and start the sander.

- Let the tool do the work. The actual weight of the machine is normally sufficient for efficient sanding. Do not put additional pressure on the machine, which would only slow down the speed of the belt, reducing efficiency and placing an additional burden on the motor.
3. Pass the sander back and forth, taking care to keep the sander moving around at all times. Avoid dwelling in one place for more than a moment.
 4. Release the trigger to stop the tool.
 5. Always ensure the tool has stopped before putting it down.

DISCONNECTING THE AIR SUPPLY

1. Do not disconnect the air supply hose until the compressor has been shut down and the compressed air released.
2. Refer to the compressor instruction manual for the procedure to shut down and vent the compressed air.
3. Once the pressure has been released, disconnect the air supply hose from the air tool.

MAINTENANCE



WARNING: MAKE SURE THAT THE AIR TOOL IS DISCONNECTED FROM THE AIR SUPPLY BEFORE STARTING ANY CLEANING OR MAINTENANCE PROCEDURES.

DAILY

1. Before use, drain water from the airline filter and compressor.
2. Pour a few drops of Clarke air-line oil, into the tool air inlet. This should be carried out regardless of whether or not an in-line mini oiler is used. If an in-line mini oiler is not used, this procedure should be repeated after every two to three hours of use.
3. Check the air inlet screen filter for blockage and clean if necessary.

CLEANING

1. Keep the body of the tool clean and free from debris.
2. Grit or gum deposits in the tool may also reduce efficiency. This condition can be corrected by cleaning the air strainer and flushing out the tool with

gum solvent oil, or failing this, the tool should be disassembled, thoroughly cleaned, dried and reassembled. This is better left to your Clarke dealer.

3. After extensive use, remove the inlet screen filter and flush out the mechanism with gum solvent oil or an equal mixture of Clarke air-line oil and paraffin. Allow to dry before use.



4. If the tool runs erratically or becomes inefficient, and the air supply is of good quality, it may be necessary to dismantle the air motor and replace worn or damaged parts. You may prefer to take the tool to your Clarke dealer if internal maintenance is required.

PERFORMANCE

Please note that factors other than the tool may effect its operation and efficiency such as reduced compressor output, excessive drain on the airline, moisture or restrictions in the air-line, or the use of connectors of improper size or poor condition which will reduce air supply.

**Clarke Air Line Oil (part no. 3050825) is available from your Clarke dealer.

Your Clarke air tool has been designed to give long and trouble free service. If, however, having followed the instructions in this booklet carefully, you encounter problems, take the unit to your local Clarke dealer.

STORAGE

When not in use, disconnect from air supply, clean & store in a safe, dry place. If the tool is to be stored, or is idle for longer than 24 hours, run a few drops of Clarke air line oil into the air inlet, and run the tool for 5 seconds in order to lubricate the internal parts.

ACCESSORIES

A wide range of accessories is available including filter/regulators, lubricators, high-pressure hoses (5 to 50 metres) etc. Contact your Clarke dealer for further information.

ABRASIVE BELTS

Replacement abrasive belts are available from your CLARKE dealer:

60 grit (pack of 5) Part no. 3110751

80 grit (pack of 5) Part no. 3110752

TROUBLESHOOTING

SYMPTOM	PROBLEM	SOLUTION
Tool runs at normal speed but slows down under any load.	<ol style="list-style-type: none"> 1. Motor parts worn. 2. Worn or sticking mechanism due to lack of lubricant. 	<ol style="list-style-type: none"> 1. Return to Clarke dealer for repair. 2. Drip air tool lubricating oil into air inlet. Allow oil to soak moving parts before using.
Tool runs slowly. Air flows weakly from exhaust.	<ol style="list-style-type: none"> 1. Motor parts jammed with gum/dirt. 2. Air-line regulator in closed position. 3. General airflow blocked by dirt. 	<ol style="list-style-type: none"> 1. Examine inlet air filter for blockage. Drip a few drops of air tool lubricating oil into air inlet. 2. Adjust in-line regulator to open position. 3. Operate tool in short bursts.
Tool will not run. Air flows freely from exhaust.	<ol style="list-style-type: none"> 1. Motor vanes stuck due to buildup of foreign material. 	<ol style="list-style-type: none"> 1. Disconnect air supply and rotate tool assembly manually. 2. Try operating tool in short bursts. 3. Tap motor housing gently with a rubber mallet. 4. Drip a few drops of air tool lubricating oil into air inlet to soak moving parts.
Tool will not shut off.	<ol style="list-style-type: none"> 1. Throttle O-rings damaged or ill-fitting in seat. 	<ol style="list-style-type: none"> 1. Return to Clarke dealer for repair.

PARTS LIST

No	Description
1	Idle Pulley Arm Assy
2	Idle Pulley Assy
2A	Socket Head Bolt 5x28
2B	Washer
2C	Circlip
3	Spring
4	Finger Pad Assy
5	Key Bolt Assy
6	Socket Head Bolt 5x12
7	Sanding Belt
8	Socket Head Bolt 6x16
8A	Washer
9	Drive Pulley
10	Flat Shoe
11	Socket Head Bolt 5x118
12	Dust Guard
13	Guard Body
14	Tension Bar
15	Spring
16	Lever Pin
17	Lever Pin
18	Main Housing
19	Ball Bearing EE3

No	Description
20	End Plate B
21	Spacer 10 x 13 x 3
22	Sunk Key 2x2.5x 10
23	Cap
24	Bearing 626ZZ
25	End Plate A
26	Cylinder
27	Blade Set
28	Rotor
29	Throttle Lever
30	Lever Hinge Pin
31	Valve Body
32	O-Ring
33	O-Ring
34	O-Ring
35	Valve Stem
36	O-Ring
37	Valve Spring
38	Exhaust Deflector
39	Air Inlet
40	Hex Key 4mm
7	Sanding Belt 80 grit
7	Sanding Belt 100 grit

When requesting replacement parts, please quote part ref; KL0707001 to KL0707040.

PARTS DIAGRAM

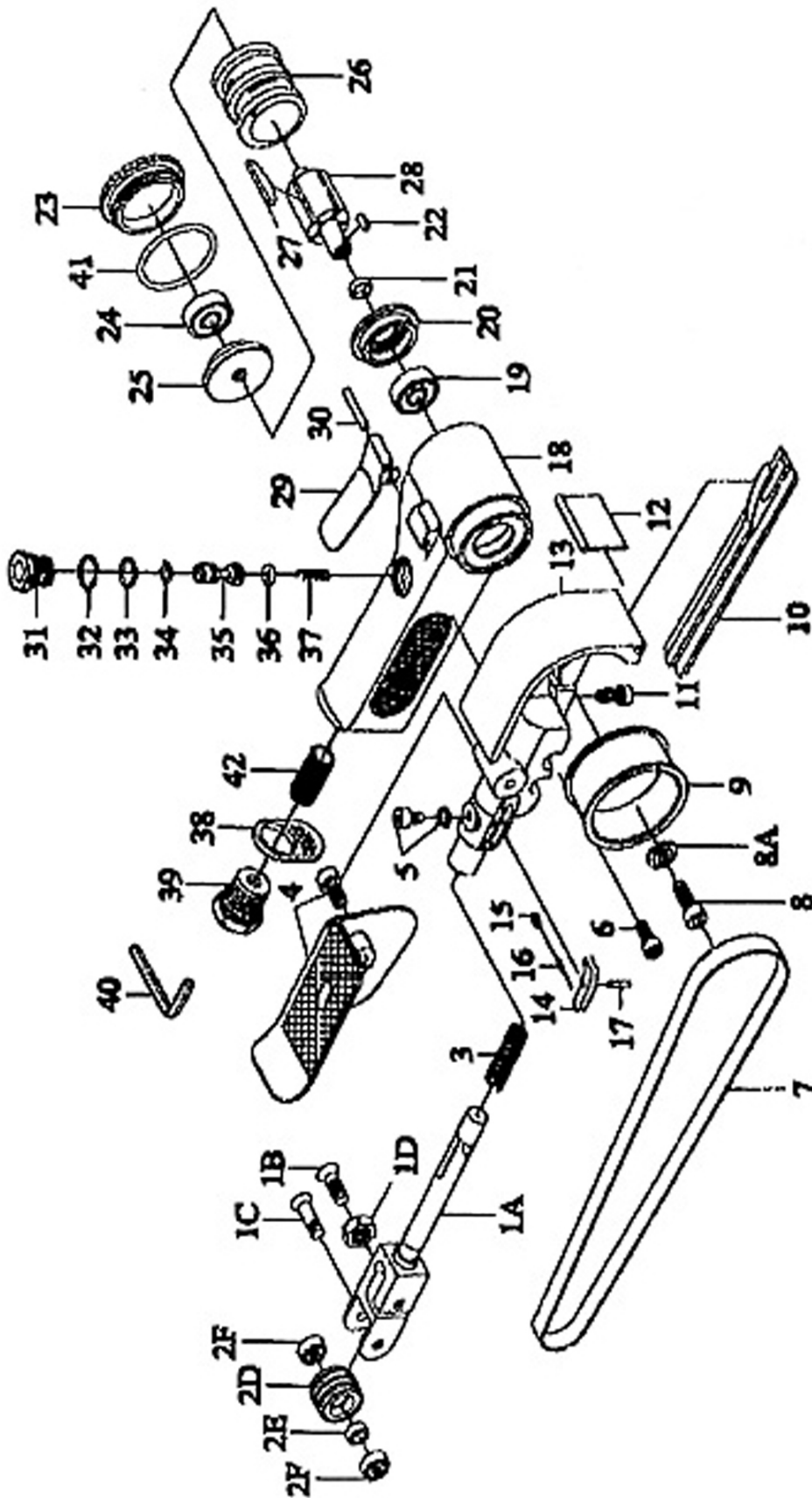

SPECIFICATION

Model Number	CAT70
Part Number	3110750
Min. Hose Size (ID)	1/4" BSP
Max Operating Pressure	90 psi (6.2 bar)
Air Consumption	17 cfm (max) / nominal 12 cfm
Belt Speed	1500 m/min @ 90psi
Air Inlet Size	1/4" BSP
Sound Pressure Level (LpA dB)	99 dB(A)
Sound Power Level (LwA dB)	88 dB(A)
Uncertainty Factor	3 dB
Vibration Levels	0.58 m/s ² (uncertainty factor K= 1.5 m/s ²)
Weight	1.2 kg
Sanding Belt Size	20 mm x 520 mm

Please note that the details and specifications contained herein are correct at the time of going to print. However Clarke International reserve the right to change specifications at any time without prior notice.

DECLARATION OF CONFORMITY



Hemnal Street, Epping, Essex CM16 4LG

DECLARATION OF CONFORMITY

This is an important document and should be retained.

We hereby declare that this product(s) complies with the following statutory requirement(s):

Supply of Machinery (Safety) Regulations 2008

The following standards have been applied to the product(s):

EN ISO 11148-8:2011

The technical documentation required to demonstrate that the product(s) meet(s) the requirement(s) of the aforementioned legislation has been compiled and is available for inspection by the relevant enforcement authorities.

The UKCA mark was first applied in: 2022

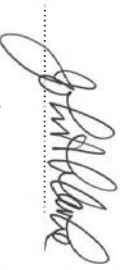
Product Description: Heavy Duty Air Belt Sander
Model number(s): CAT70
Serial / batch Number: N/A
Date of issue: 30/11/2022
Signed: 

J.A. Clarke
Director

CAT70 UKCA Clarke DOC 113022

Page 1 of 1



Fitzwilliam Hall, Fitzwilliam Place, Dublin 2

DECLARATION OF CONFORMITY

This is an important document and should be retained.

We hereby declare that this product(s) complies with the following directive(s):

2006/42/EC Machinery Directive

The following standards have been applied to the product(s):

EN ISO 11148-8:2011

The technical documentation required to demonstrate that the product(s) meet(s) the requirement(s) of the aforementioned directive(s) has been compiled and is available for inspection by the relevant enforcement authorities.

The CE mark was first applied in: 2010

Product Description: Heavy Duty Air Belt Sander
Model number(s): CAT70
Serial / batch Number: N/A
Date of issue: 30/11/2022
Signed: 

J.A. Clarke
Director

CAT70 CE Clarke DOC 113022

Page 1 of 1

A SELECTION FROM THE VAST RANGE OF

Clarke®

QUALITY PRODUCTS



AIR COMPRESSORS
From DIY to industrial, Plus air tools, spray guns and accessories.

GENERATORS
Prime duty or emergency standby for business, home and leisure.

POWER WASHERS
Hot and cold, electric and engine driven - we have what you need

WELDERS
Mig, Arc, Tig and Spot. From DIY to auto/industrial.

METALWORKING
Drills, grinders and saws for DIY and professional use.

WOODWORKING
Saws, sanders, lathes, mortisers and dust extraction.

HYDRAULICS
Cranes, body repair kits, transmission jacks for all types of workshop use.

WATER PUMPS
Submersible, electric and engine driven for DIY, agriculture and industry.

POWERTOOLS
Angle grinders, cordless drill sets, saws and sanders.

STARTERS/CHARGERS
All sizes for car and commercial use.



PARTS & SERVICE: 0208 988 7400

Parts Enquiries
Parts@clarkeinternational.com

Servicing & Technical Enquiries
Service@clarkeinternational.com

SALES: UK 01992 565333 or Export 00 44 (0)1992 565335

Clarke® INTERNATIONAL Hemnall Street, Epping, Essex CM16 4LG
www.clarkeinternational.com